

**Protective sliders
SUZUKI GSR 750**

Year of production: '11-
Product code: 10324

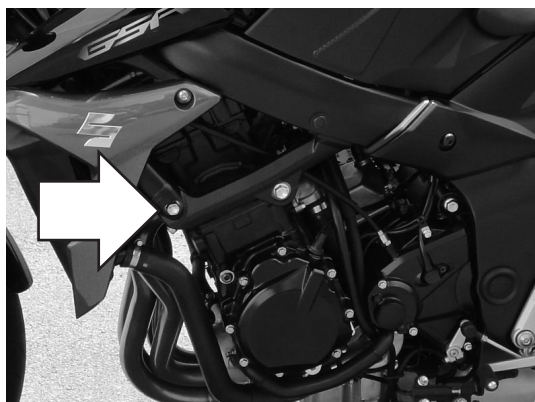

Assembly position / Left side



Assembly position / Right side

Assembly instructions

1. Remove the screws indicated with the arrows.
2. Replace the removed screws by the new screws (parts #4) and metal bars (parts #2) according to the attached drawing. Put the metal parts (parts #2) in the right positions according to the drawing.
3. Assemble the sliders and the screws according to the drawing (parts #1, #6, #5).
4. Assemble the screws #5 and the sliders with the metal bars #2.

We suggest to use the threadlocker to make sure that the screws do not get loose.

This product is entirely produced in the European Union. This product is a professional accessory to be used on the race track. Renner LTD takes no responsibility for any damages occurred despite of using protective accessories. For more information go to www.renner-moto.com

Assembly scheme (both sides)

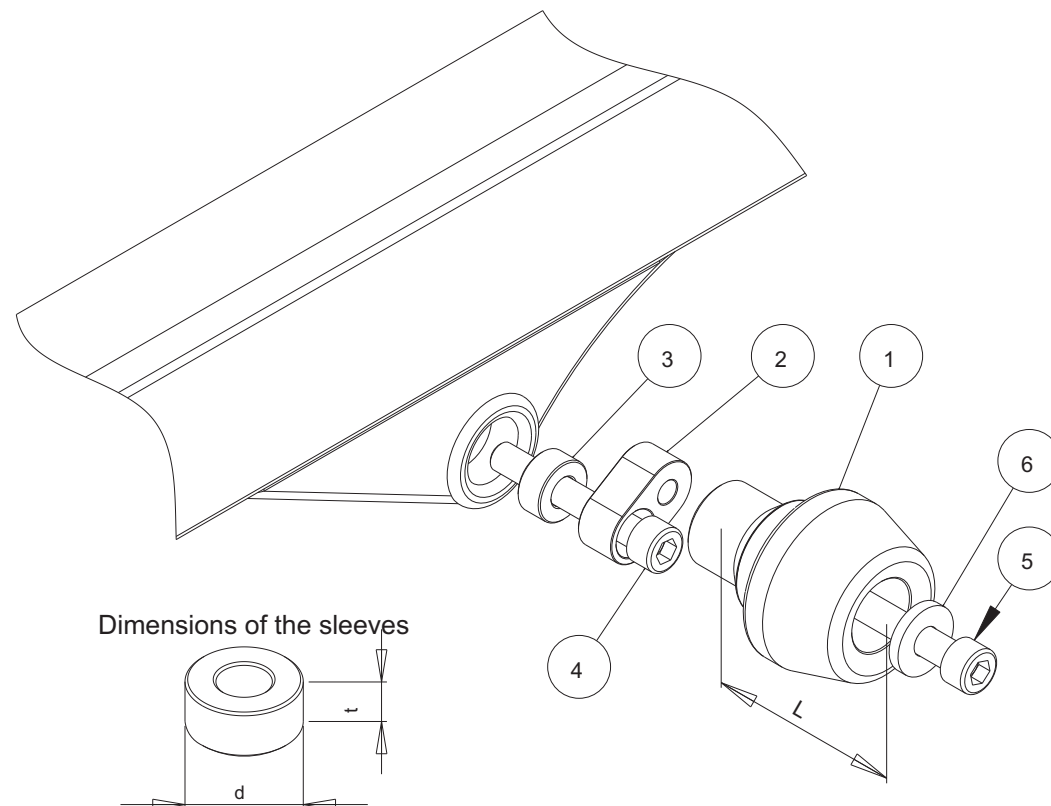

No	Part	Left side	Right side
1	Slider	L = 55 mm	L = 55 mm
2	Metal bar		
3	Sleeve	d=22 mm, t=20 mm	d=22 mm, t=15 mm
4	Main screw	M10, L = 70 mm	M10, L = 60 mm
5	Screw	M10	M10
6	Washer		